



**BULLARD
BOLLARDS**
Think Bullard Think Bullard



WARE

ILLUMINATED **SECURITY & SAFETY BOLLARDS**

SC40
RATING



Fixture Type:

Project Name:



General Information:

A straightforward approach to safety and visibility, WARE combines durable protection with integrated lighting to create safer outdoor environments. Its strong construction provides reliable defense against vehicle intrusion, while illumination improves clarity and comfort after dark.

Designed for versatility, it integrates easily into a wide range of landscapes while maintaining a clean, approachable presence.

Applications: outdoor spaces, pathways, general perimeter protection

Fixture Type:

Illuminated Security & Safety Bollard

Lighting:

LED

Voltage:

110-277V

Material:

Stainless Steel, Carbon Steel, Aluminum

Driver Position:

Integral

IP Rating:

IP 65

Appliance Class:

I

Warranty:

LED lighting products are warranted for 5 years.

Main Features:

- High visual comfort
- Available in a wide range of finishes
- Functional and minimalistic design
- Shock-resistant construction
- Operating Temperature: -22°F to +122°F.



Due to the dynamic nature of lighting products and the associated technologies, luminaire data on all specification sheets is subject to change at the discretion of Gordon Bullard LLC and associated companies.

THINK BOLLARD - THINK BULLARD

sales@gordonbullard.com / www.bullardbollards.com / 1-877-964-4646

991 South Gull Lake Dr Richland, MI 49083 USA



Fixture Type:

Project Name:

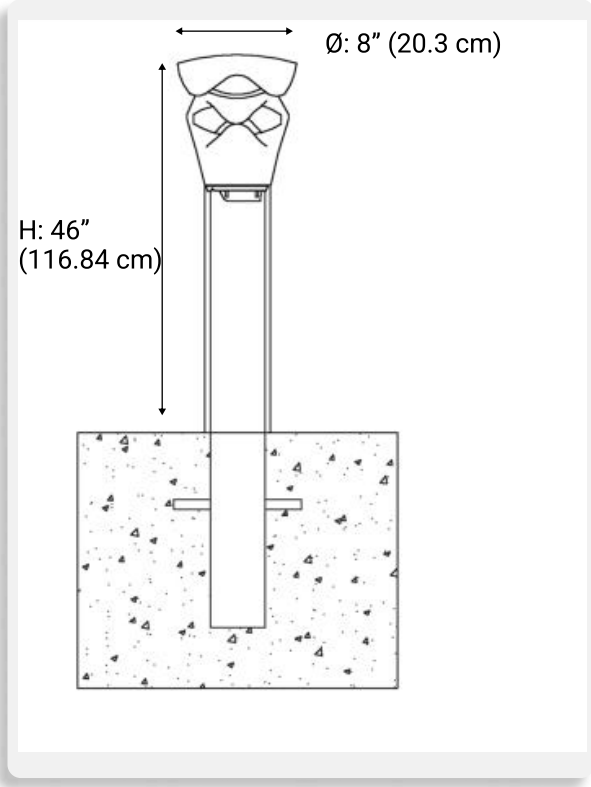

HOW TO ORDER:

CODE:

CODE EXAMPLE:
BB-WRE-GLC-SC40-LSB20-K30-DIM-WH

BB-WRE-GLC-SC40-LSB20-K30-DIM-WH

1 DIMENSIONS:

Diameter - Ø: 8" (20.3 cm)
Overall Height - H: 46" (116.84 cm)
-Cus Custom height on request*

2 LIGHT SOURCE OUTPUT BOLLARD:

-LSB20 9 W / 720 lm / CRI 90
-LSBC Custom Lumen packages on request*

3 CCT:

-K30 3000K
-K35 3500K
-K40 4000K

4 DIMMING OPTIONS:

-NON NON-Dimmable
-DIM 0-10V

5 FINISH OPTIONS:

-WH White (RAL 9010)
-BL Black (RAL 9005)
-BR Bronze (RAL 8004)
-LG Light Grey (RAL 7047)
-DK Dark Grey (RAL 7021)
-BSS Brushed Stainless Steel
-CUS Custom on request*



Due to the dynamic nature of lighting products and the associated technologies, luminaire data on all specification sheets is subject to change at the discretion of Gordon Bullard LLC and associated companies.

THINK BOLLARD - THINK BULLARD

sales@gordonbullard.com / www.bullardbollards.com / 1-877-964-4646
991 South Gull Lake Dr Richland, MI 49083 USA

ASTM CRASH RATINGS EXPLAINED

ASTM crash ratings (ASTM F2656) are a U.S. standard used to classify the performance of vehicle security barriers based on their ability to stop a 15,000 lb (6,800 kg) truck at defined impact speeds. The rating combines impact speed—M30 (30 mph), M40 (40 mph), or M50 (50 mph)—with a penetration level (P1, P2, P3), indicating how far the vehicle travels past the barrier after impact, providing a clear benchmark for selecting appropriate protection against specific vehicle-borne threats.

THE RATING CATEGORIES BREAK DOWN AS FOLLOWS:

SC  (SC) Small Passenger Car

- Vehicle weight: 2,430 lbs
- Speed ratings: SC40 (40 mph), SC50 (50 mph), SC60 (60 mph)
- Use case: Low-mass vehicle threats; urban or light-security environments

PU  (PU) Pickup Truck

- Vehicle weight: 5,070 lbs
- Speed ratings: PU40 (40 mph), PU50 (50 mph), PU60 (60 mph)
- Use case: Mid-range threats; commercial zones, parking perimeters

M  (M) Medium-Duty Truck

- Vehicle weight: 15,000 lbs
- Speed ratings: M30 (30 mph), M40 (40 mph), M50 (50 mph)
- Use case: Elevated risk scenarios; logistics hubs, public infrastructure



Due to the dynamic nature of lighting products and the associated technologies, luminaire data on all specification sheets is subject to change at the discretion of Gordon Bullard LLC and associated companies.

THINK BOLLARD - THINK BULLARD

sales@gordonbullard.com / www.bullardbollards.com / 1-877-964-4646

991 South Gull Lake Dr Richland, MI 49083 USA

FOUNDATION OPTIONS EXPLAINED

Understanding foundation type and depth is critical to ensure the bollard performs as designed under impact. Improper installation can significantly reduce crash-rating effectiveness and compromise site safety.



Deep Foundation

- **Excavation: 30" (762 mm) depth**
- **Reinforcement: Rebar cage (#5 / #8)**
- **Installation: Bollard embedded and fully encased in concrete**
- **Function: Transfers impact load into deep concrete mass**



Due to the dynamic nature of lighting products and the associated technologies, luminaire data on all specification sheets is subject to change at the discretion of Gordon Bullard LLC and associated companies.

THINK BOLLARD - THINK BULLARD

sales@gordonbullard.com / www.bullardbollards.com / 1-877-964-4646

991 South Gull Lake Dr Richland, MI 49083 USA